

User Manual

BG2000 Series Barrier Gate (APP Version)

Date: June 2022

Doc Version: 1.1

English

Thank you for choosing our product. Please read the instructions carefully before operation. Follow these instructions to ensure that the product is functioning properly. The images shown in this manual are for illustrative purposes only.



For further details, please visit our Company's website
www.zkteco.in.

Copyright © 2022 ZKTECO CO., LTD. All rights reserved.

Without the prior written consent of ZKTeco, no portion of this manual can be copied or forwarded in any way or form. All parts of this manual belong to ZKTeco and its subsidiaries (hereinafter the "Company" or "ZKTeco").

Trademark

ZKTeco is a registered trademark of ZKTeco. Other trademarks involved in this manual are owned by their respective owners.

Disclaimer

This manual contains information on the operation and maintenance of the ZKTeco equipment. The copyright in all the documents, drawings, etc. in relation to the ZKTeco supplied equipment vests in and is the property of ZKTeco. The contents hereof should not be used or shared by the receiver with any third party without the express written permission of ZKTeco.

The contents of this manual must be read as a whole before starting the operation and maintenance of the supplied equipment. If any of the content(s) of the manual seems unclear or incomplete, please contact ZKTeco before starting the operation and maintenance of the said equipment.

It is an essential pre-requisite for the satisfactory operation and maintenance that the operating and maintenance personnel are fully familiar with the design and that the said personnel have received thorough training in operating and maintaining the machine/unit/equipment. It is further essential for the safe operation of the machine/unit/equipment that personnel has read, understood and followed the safety instructions contained in the manual.

In case of any conflict between terms and conditions of this manual and the contract specifications, drawings, instruction sheets or any other contract-related documents, the contract conditions/documents shall prevail. The contract specific conditions/documents shall apply in priority.

ZKTeco offers no warranty, guarantee or representation regarding the completeness of any information contained in this manual or any of the amendments made thereto. ZKTeco does not extend the warranty of any kind, including, without limitation, any warranty of design, merchantability or fitness for a particular purpose.

ZKTeco does not assume responsibility for any errors or omissions in the information or documents which are referenced by or linked to this manual. The entire risk as to the results and performance obtained from using the information is assumed by the user.

ZKTeco in no event shall be liable to the user or any third party for any incidental, consequential, indirect, special, or exemplary damages, including, without limitation, loss of business, loss of profits, business interruption, loss of business information or any pecuniary loss, arising out of, in connection

with, or relating to the use of the information contained in or referenced by this manual, even if ZKTeco has been advised of the possibility of such damages.

This manual and the information contained therein may include technical, other inaccuracies or typographical errors. ZKTeco periodically changes the information herein which will be incorporated into new additions/amendments to the manual. ZKTeco reserves the right to add, delete, amend or modify the information contained in the manual from time to time in the form of circulars, letters, notes, etc. for better operation and safety of the machine/unit/equipment. The said additions or amendments are meant for improvement /better operations of the machine/unit/equipment and such amendments shall not give any right to claim any compensation or damages under any circumstances.

ZKTeco shall in no way be responsible (i) in case the machine/unit/equipment malfunctions due to any non-compliance of the instructions contained in this manual (ii) in case of operation of the machine/unit/equipment beyond the rate limits (iii) in case of operation of the machine and equipment in conditions different from the prescribed conditions of the manual.

The product will be updated from time to time without prior notice. The latest operation procedures and relevant documents are available on <http://www.zkteco.in>.

If there is any issue related to the product, please contact us.

ZKTeco Biometric India Pvt Ltd.

Address B-1, Khata No.31, Devasandra Industrial Estate,
Whitefield Main Road, Beside Phoenix Mall,
Mahadevapura, Bengaluru, Karnataka.

Phone 080 8628 1342

For business-related queries, please write to us at sales@zkteco.in.

To know more about our global branches, visit www.zkteco.in.

About the Company

ZKTeco is one of the world's largest manufacturer of RFID and Biometric (Fingerprint, Facial, Finger-vein) readers. Product offerings include Access Control readers and panels, Near & Far-range Facial Recognition Cameras, Elevator/floor access controllers, Turnstiles, License Plate Recognition (LPR) gate controllers and Consumer products including battery-operated fingerprint and face-reader Door Locks. Our security solutions are multi-lingual and localized in over 18 different languages. At the ZKTeco state-of-the-art 700,000 square foot ISO9001-certified manufacturing facility, we control manufacturing, product design, component assembly, and logistics/shipping, all under one roof.

The founders of ZKTeco have been determined for independent research and development of biometric verification procedures and the productization of biometric verification SDK, which was initially widely applied in PC security and identity authentication fields. With the continuous enhancement of the development and plenty of market applications, the team has gradually constructed an identity authentication ecosystem and smart security ecosystem, which are based on biometric verification techniques. With years of experience in the industrialization of biometric verifications, ZKTeco was officially established in 2007 and now has been one of the globally leading enterprises in the biometric verification industry owning various patents and being selected as the National High-tech Enterprise for 6 consecutive years. Its products are protected by intellectual property rights.

About the Manual

This manual introduces the operations of BG1000 Series Barrier Gate (APP Version).

All figures displayed are for illustration purposes only. Figures in this manual may not be exactly consistent with the actual products.

Document Conventions

Conventions used in this manual are listed below:

GUI Conventions

For Software	
Convention	Description
Bold font	Used to identify software interface names e.g., OK, Confirm, Cancel.
>	Multi-level menus are separated by these brackets. For example, File > Create > Folder.
For Device	
Convention	Description
< >	Button or key names for devices. For example, press <OK>.
[]	Window names, menu items, data table, and field names are inside square brackets. For example, pop up the [New User] window.
/	Multi-level menus are separated by forwarding slashes. For example, [File/Create/Folder].

Symbols





Convention	Description
	This represents a note that needs to pay more attention to.
	The general information which helps in performing the operations faster.
	The information which is significant.
	Care taken to avoid danger or mistakes.
	The statement or event that warns of something or that serves as a cautionary example.

Table of Contents

1	OVERVIEW.....	7
2	FEATURES AND FUNCTIONALITIES	7
3	SPECIFICATIONS.....	8
4	APPEARANCE AND DIMENSIONS	9
5	LEFT AND RIGHT DIRECTIONS	9
6	INSTALLATION PROCEDURE.....	10
	6.1 INSTALLATION PRECAUTIONS.....	10
	6.2 CABLE EMBEDDING.....	10
	6.3 BOOM ARM INSTALLATION	10
	6.3.1 BOOM ARM INSTALLATION PROCEDURE	10
7	MAINBOARD WIRING INSTRUCTIONS.....	12
	7.1 WIRE CONNECTION OF THE NEW MAINBOARD.....	12
	7.2 CONNECTION WITH LPR CAMERA.....	12
	7.3 CONNECTION WITH UHF SYSTEM.....	13
	7.4 CONNECTION WITH LOOP DETECTOR.....	14
	7.5 CONNECTION WITH VR10 RADAR SENSOR	15
	7.6 CONNECTION WITH INFRARED/PHOTOCELL DETECTOR	16
	7.7 CONNECTION WITH DEVICE’S WI-FI	18
8	FUNCTIONAL PARAMETER SETTINGS	20
	8.1 MAINBOARD PARAMETER SETTINGS.....	20
	8.1.1 OPERATING PROCEDURE.....	20
	8.2 PARAMETER SETTINGS DESCRIPTION	21
	8.3 ERROR CODE	24
	8.4 REMOTE CONTROL PAIRING AND UNPAIRING(SUPPORT SETTING ON THE ZKBARRIER APP)	24
	8.4.1 PAIRING.....	24
	8.4.2 UNPAIRING.....	25
	8.5 SET DELAY FOR AUTOMATIC CLOSING AFTER OPENING THE BOOM ARM(SUPPORT SETTING ON THE ZKBARRIER APP)	25
9	BOOM ARM ADJUSTMENTS	26
	9.1 DIMENSIONS	26
	9.2 HORIZONTAL AND VERTICAL ANGLE ADJUSTMENT OF BOOM ARM (MECHANICAL ADJUSTMENT)	26

9.3	DIRECTION INTERCHANGE OF THE BOOM ARM.....	28
9.4	SPRING ADJUSTMENT	28
10	PRODUCT PACKING LIST	29
11	TROUBLESHOOTING	30
12	SAFETY PRECAUTIONS.....	32
13	TRANSPORTATION AND STORAGE	32
14	WARRANTY	32

1 Overview

BG2000 series barrier gate adopts an elegant chassis design with a programmable control board and a high-efficiency brushless DC motor. The built-in LED lights which indicates the on and off mode of barrier gates, suitable for large parking lot. An aluminum foam straight barrier enhances anti-collision ability and wind resistance.

It has the advantages of high speed, efficiency, stable quality, user-friendly customization, comprehensive performance, and so on. It can be used in real-time application areas such as offices, hospitals, public places, residential areas to ease traffic issues.

2 Features and Functionalities

- Support ZKBarrier APP control.
- Reversible left and right directions.
- Embedded programmable controller with Wi-Fi communication module.
- Interactive and stylish chassis LED design.
- DC 24V brushless motor with encoder.
- Barrier lift speed as fast as 0.6s.
- Automatic obstacle detection.
- 24V backup battery can be used to ensure the normal operation of the barrier when power is off.
- Emergency opening.
- Automatic delay closing (No signal trigger, loop detector delay trigger).
- Adjustable angle of rise and fall.
- Boom connector with anti-collision function.

3 Specifications

Model	BG2000L/R
Operating Speed	0.6s
Boom Arm Length	L≤3m
Boom Arm Type	Round straight boom
Chassis Dimension (L*W*H)	350*306*1070mm
Chassis Weight	45kg
Motor Type	24V DC brushless motor
Motor MCBF	5 million times
Output Power	100W
Rated Current	5A
Power Supply	Input: AC110V/220V ±10% 50/60Hz, Output: DC24V 10A
Remote Control Distance	≤30m
Operating Temperature	-30°C to 75°C
Operating Humidity	<90%
Chassis Housing Material	Powder coated cold rolled sheet
Protection level	IP54
Duty Cycle	100%
Motor Rated Speed	1500r/min

4 Appearance and Dimensions

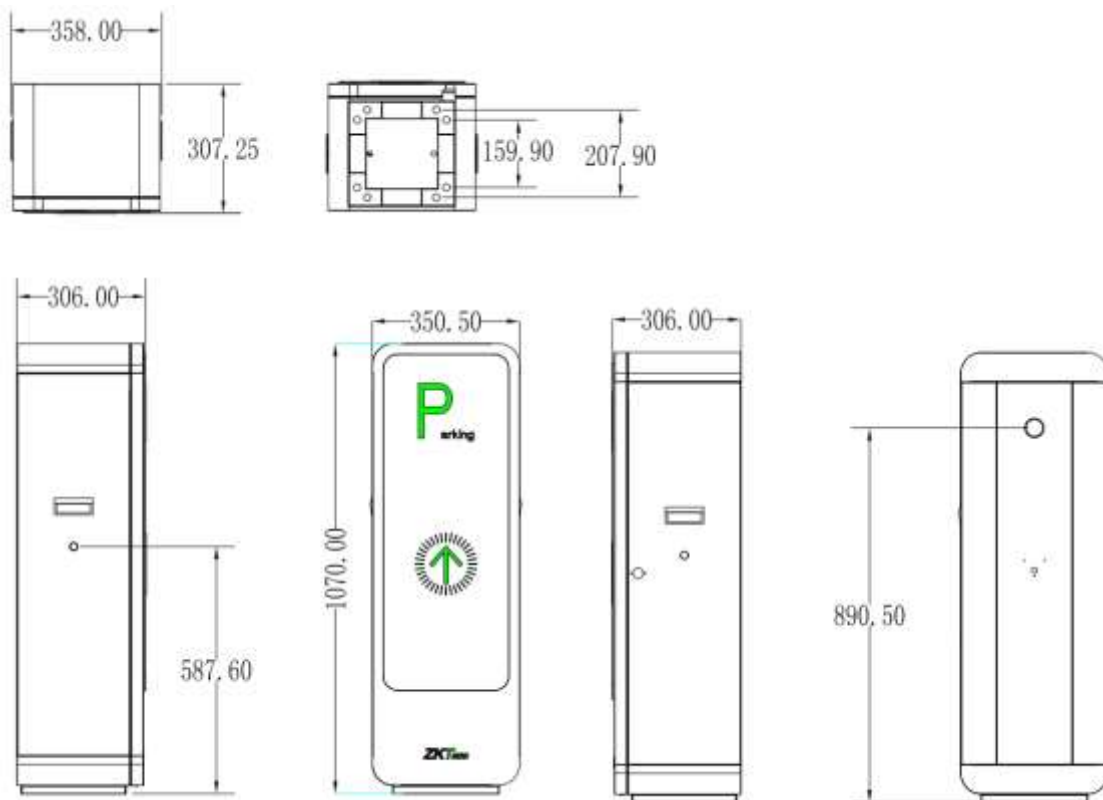

5 Left and Right Directions

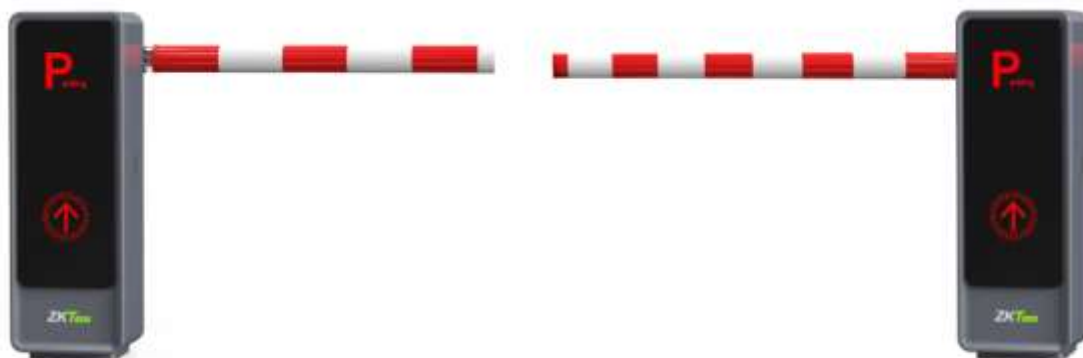

L: The chassis on the left, the boom on the right.

R: The chassis on the right, the boom on the left.

6 Installation Procedure

6.1 Installation Precautions

- Install the parking barrier on a flattened ground. A cement foundation is required before installation if the ground is not solid and flat.
- It is possible to reduce the length of the boom arm, but it cannot be increased. After the boom arm has been cut, it is important to set the spring balance again to achieve a new balance. The bottom of the spring contains two plastic nuts designed to adjust the new balance.
- When powered on, do not change the wire connection inside.
- Connect the GND to the cabinet for ensured protection.

6.2 Cable Embedding

1. A $\phi 25$ protective sleeve and a cable are required.
2. The route cables must pass through the protective sleeves.
3. Use a tool to open the cable tray on the ground.

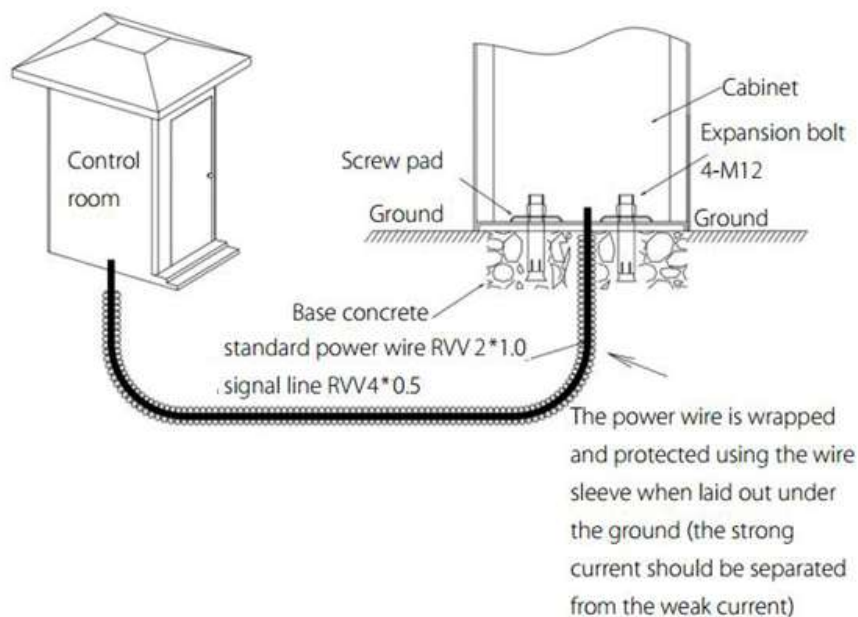

6.3 Boom Arm Installation

6.3.1 Boom Arm Installation Procedure

1. Place the boom into the boom tray head according to the hole location.
2. Use the spanner to clamp the round boom by screws, gasket, and screws nuts.

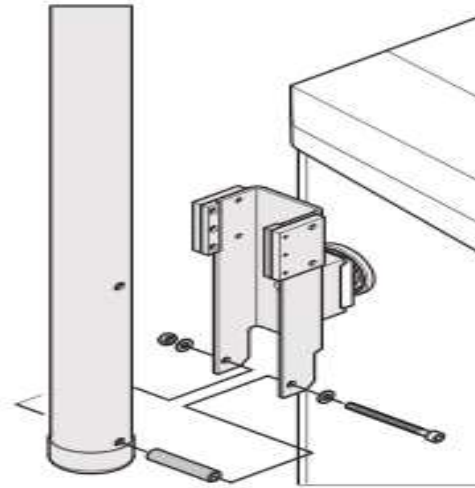

Note:

- Before the barrier is powered on to run the test process, be sure to install the barrier boom arm of the corresponding length for the test. If the barrier boom arm is not installed, please adjust and remove the spring under the guidance of a professional.
- If the length of the barrier boom arm is cut and adjusted, the tightness of the spring and the spring quantity need to be adjusted accordingly to avoid the abnormal working status that cannot drop the boom.
- During the installation of the boom, damage to the metal surface should be avoided as far as possible to avoid rusting.

7 Mainboard Wiring Instructions

- Please disconnect the power supply before wiring.
- Check carefully whether the terminals are tightened and whether the wiring is firm.

7.1 Wire Connection of the New Mainboard

Wiring diagram of new control board of the app version:

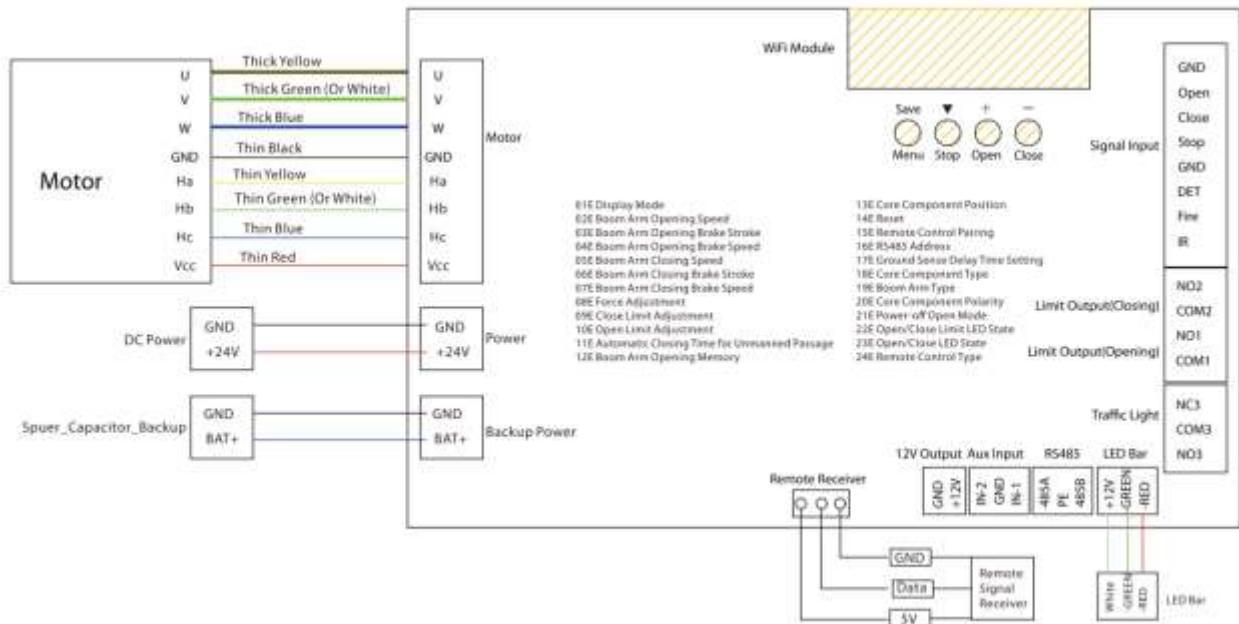

7.2 Connection with LPR Camera

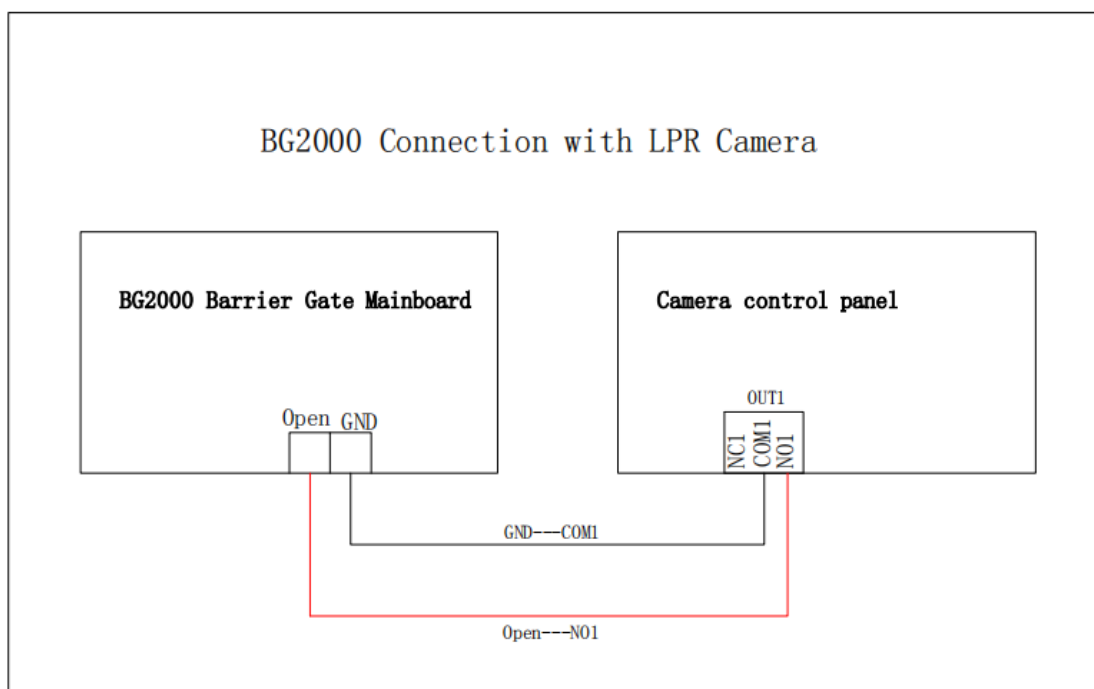

● Confirm Barrier Gate Connection with LPR Device Installation

Based on the project site planning, confirm the installation positions of exits and entrances, and then install the wiring.

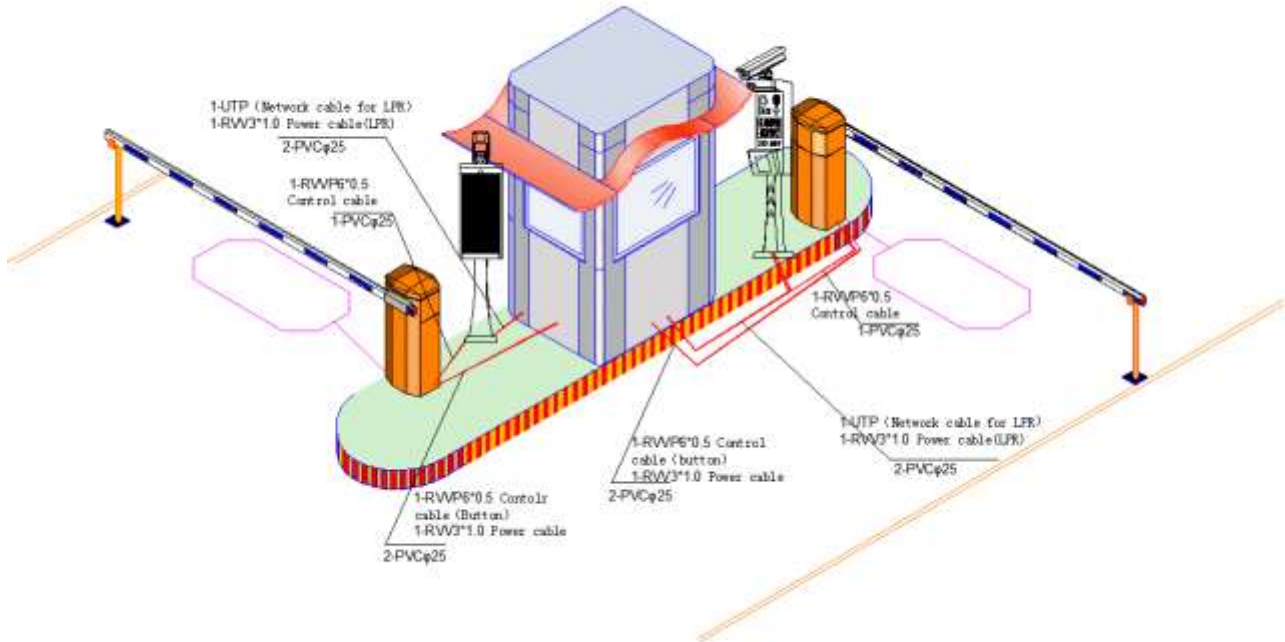

7.3 Connection with UHF System

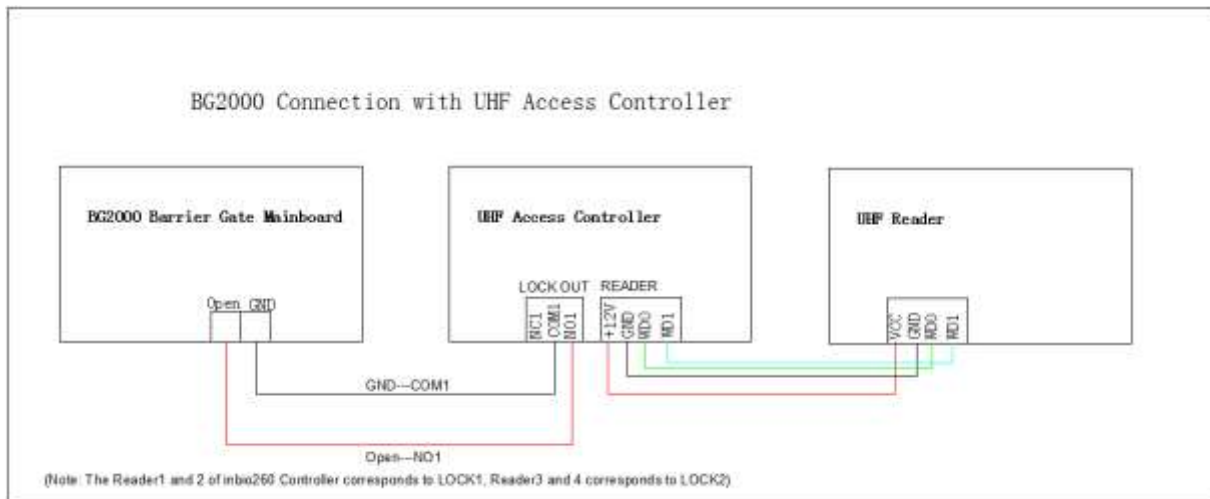

Note: The Reader1 and 2 of Inbio260 Controller corresponds to LOCK1, Reader3 and 4 corresponds to LOCK2.

- Confirm Barrier Gate Connection with UHF Device Installation

Based on the project site planning, confirm the installation positions of exits and entrances, and then install the wiring.

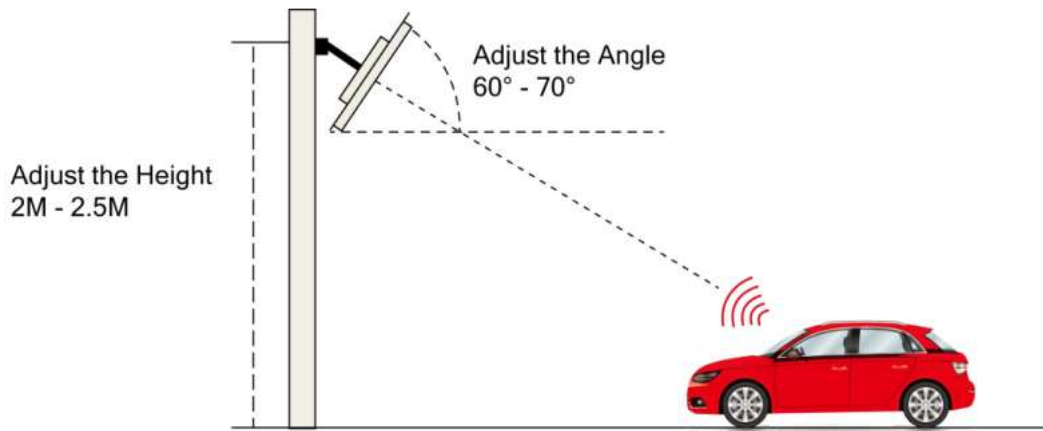

7.4 Connection with Loop Detector

- Anti-smash and Auto-close Function

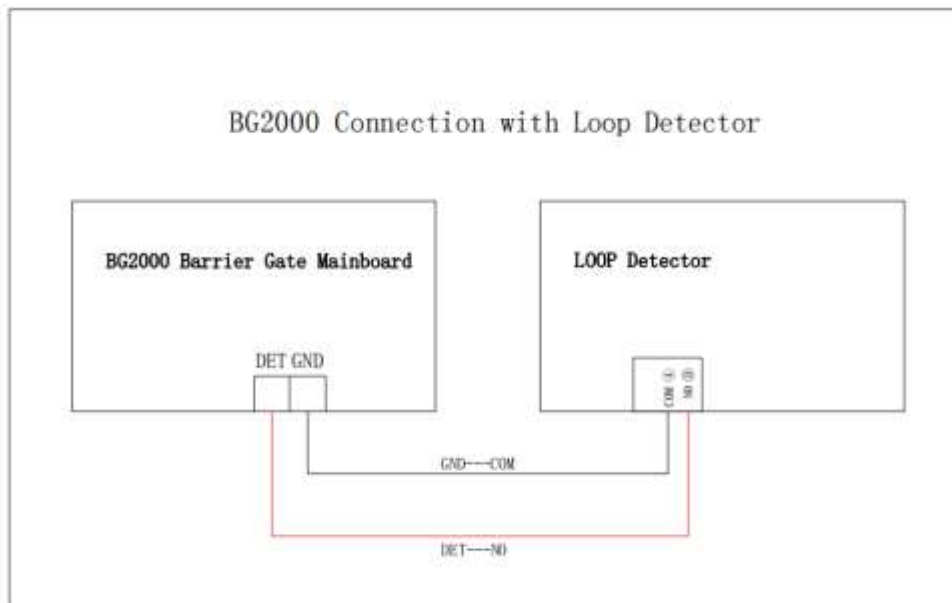

Coil Circumference	Coil Number
3m	Based on requirements, ensure that the inductance is between 100μH and 200μH.
3m to 6m	5 to 6 turns
6m to 10m	4 to 5 turns
10m to 25m	3 turns
25m	2 turns

- Confirm Loop Coil Install Position

Base on the type of lane, such as car lane type or motorcycle lane type to onfirm the length and width of the loop coil installation.

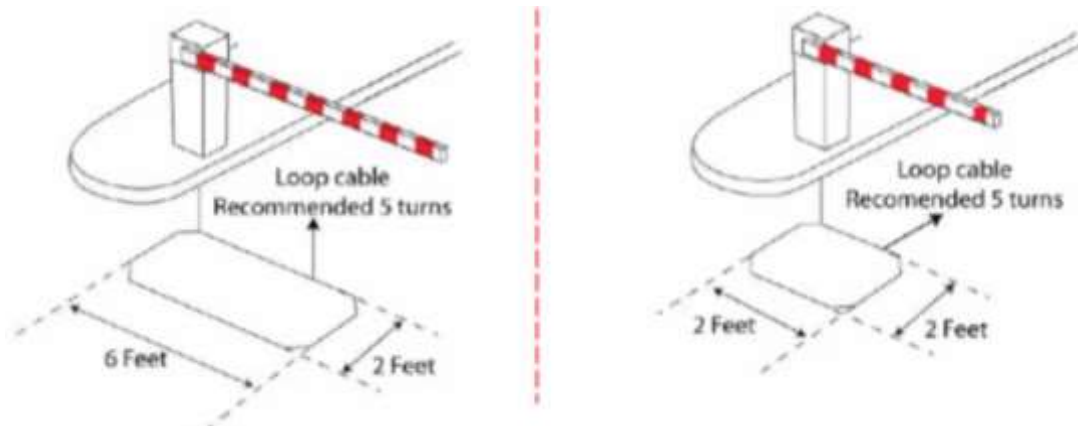

7.5 Connection with VR10 Radar Sensor

- Anti-smash and Auto-close Function

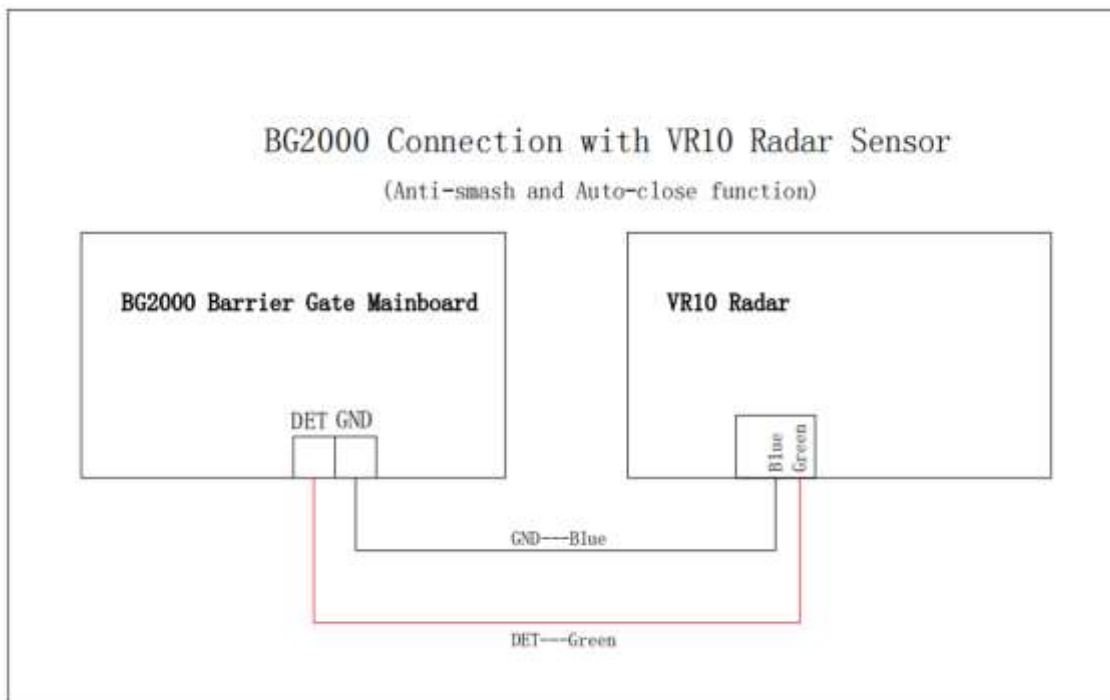

- Confirm Radar Mounting Holes

The installation hole of the radar is between 200 to 300mm from the inside of the straight boom and 650 to 800mm from the driveway ground (non-cement pier); the installation position is shown in the figure.

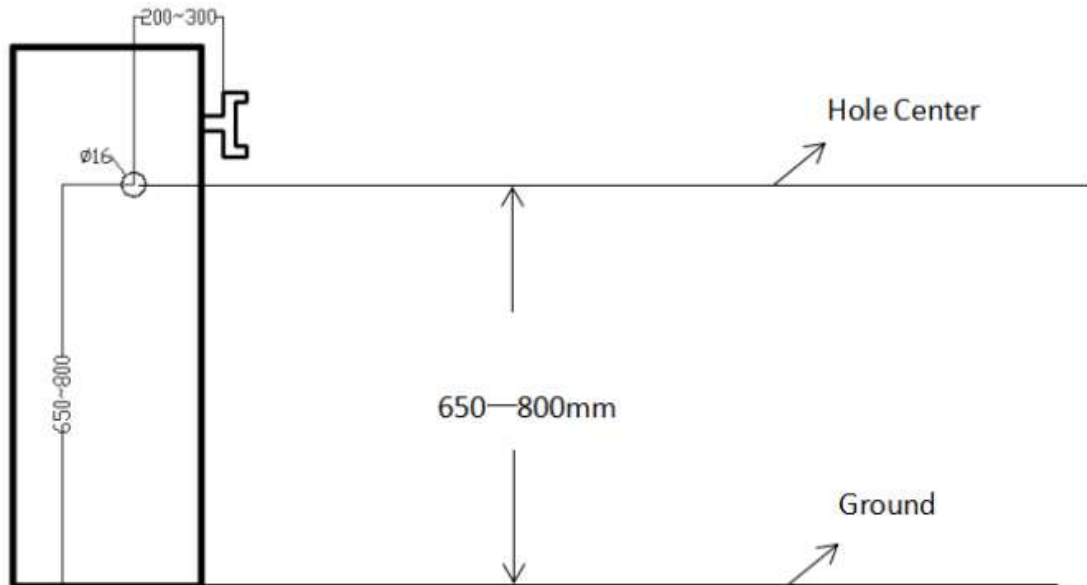

7.6 Connection with Infrared/Photocell Detector

- Anti-smash Function

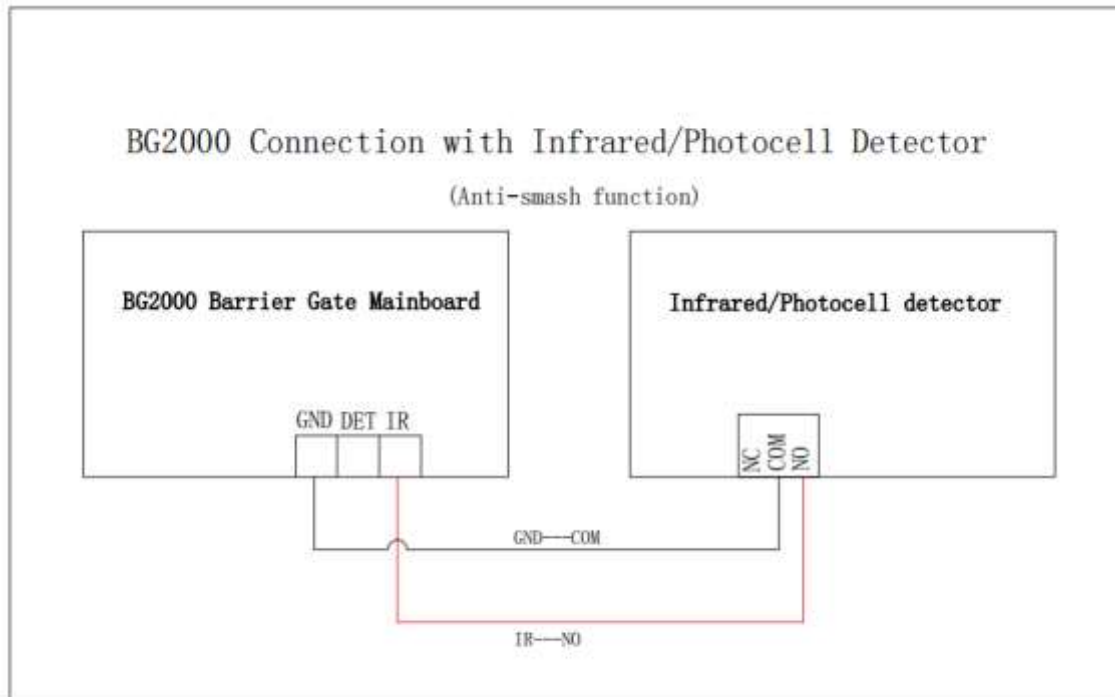

- Anti-smash and Auto-close Function

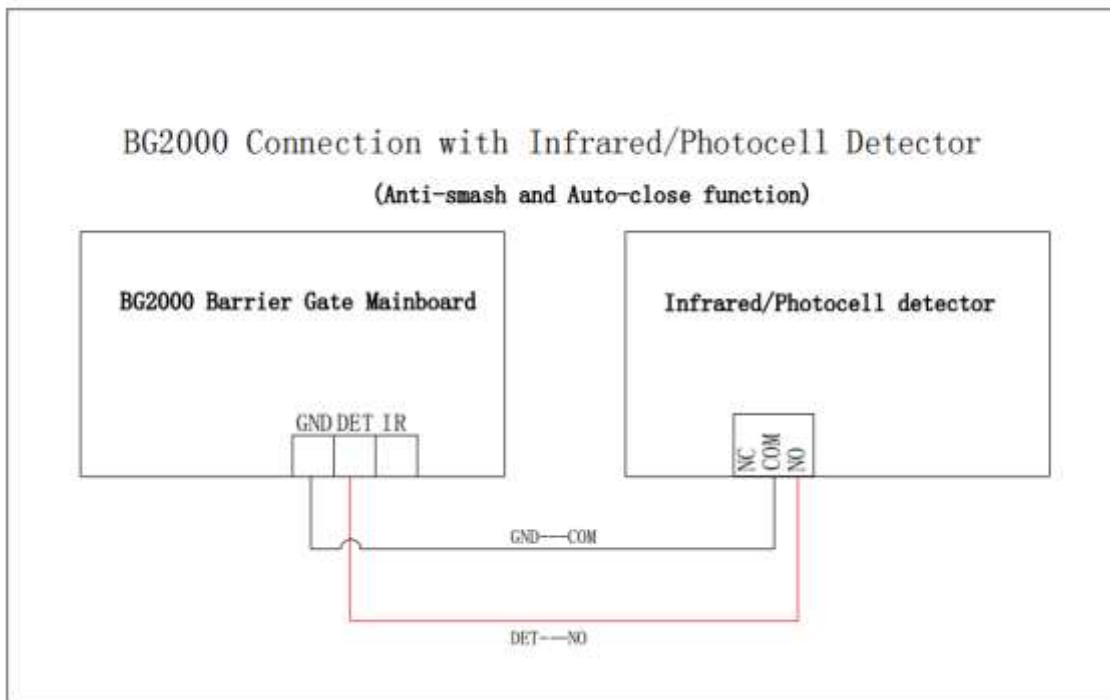

- Confirm Photocell Detector Installation

Note that the transmitter and receiver are install at the same parallel angles.

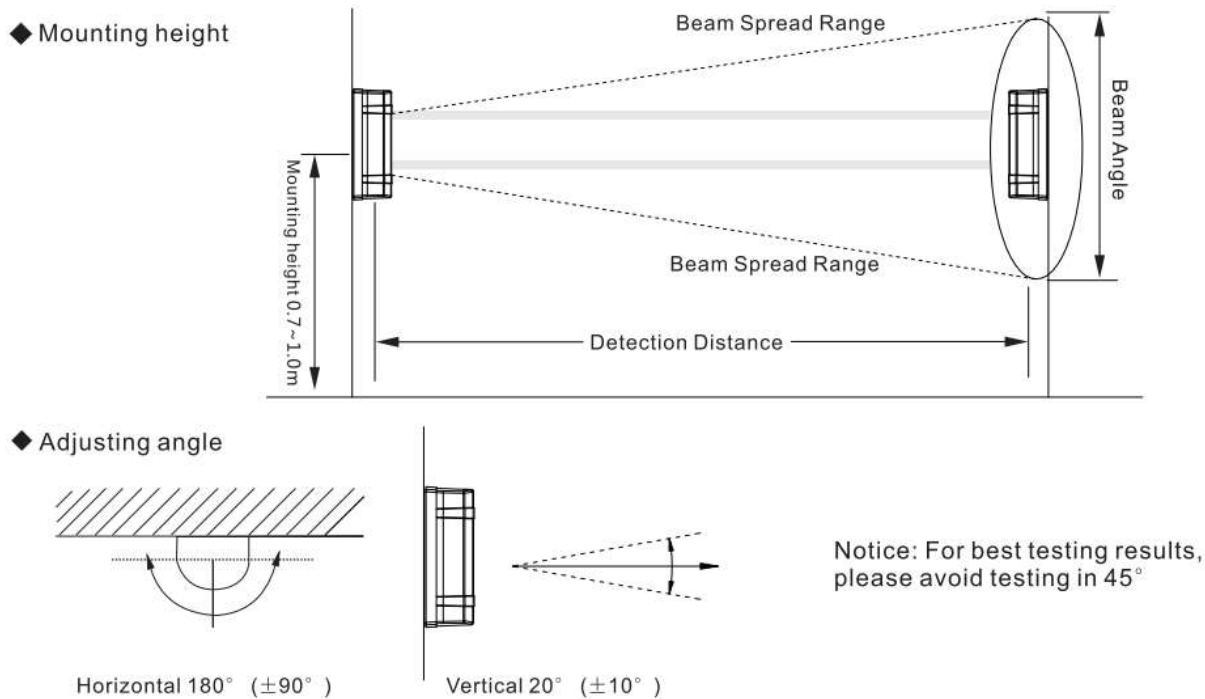

7.7 Connection with Device's Wi-Fi

The Wi-Fi function is automatically turned on after the device is powered , and the phone can also be connected to the Wi-Fi hotspot of the device after setting the function and parameters of the device through the ZKBarrier APP. It Supports both Android and iOS systems. Operation details are as follows:

1. Open the ZKBarrier APP, click Wi-Fi Connection, and then enter the connection page.
2. You can choose either Manual Connection or Scan to Connect, here take Manual Connection as an example, click Manual Connection, select the "ZKBarrier-XXXXXX" Wi-Fi name of the corresponding device, and then enter the default password 1234567890.

Note: For security reasons, it is recommended that you change the Wi-Fi connection password of your device after the first successful connection.

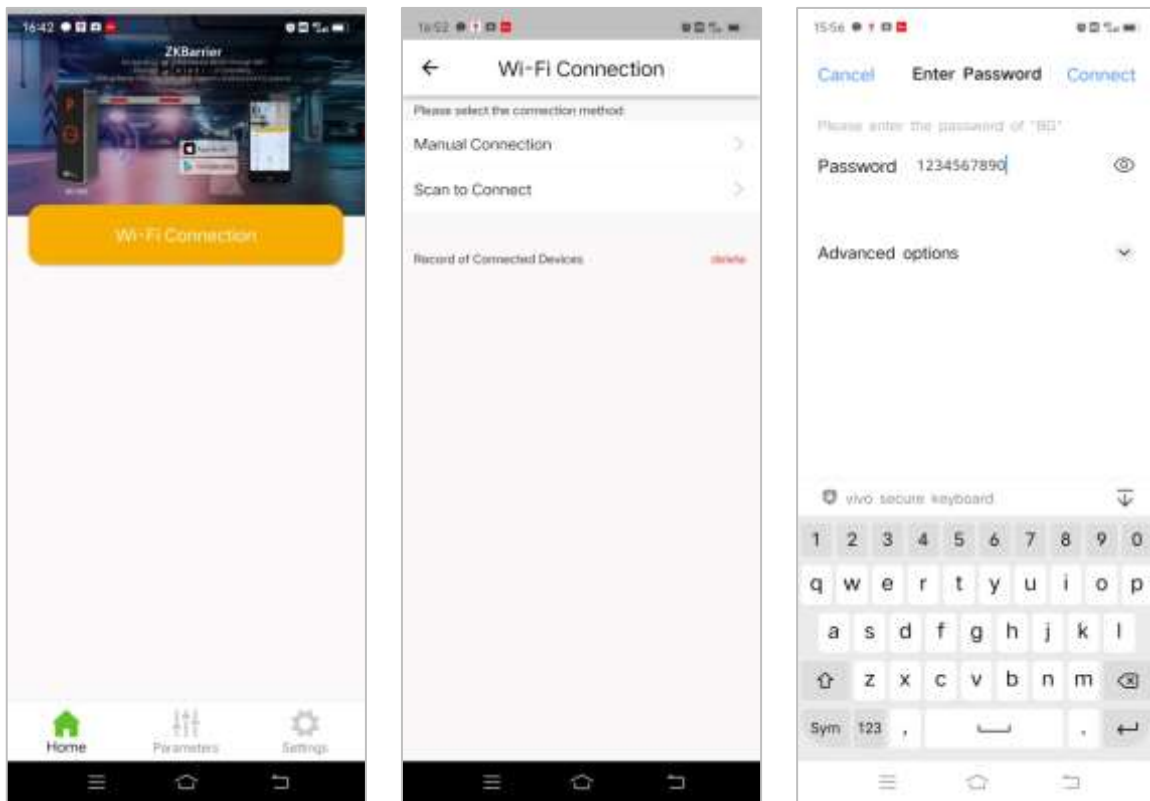

3. After successful connection, you can implement some functions and parameter settings on the APP according to the actual installation of the equipment in the field.

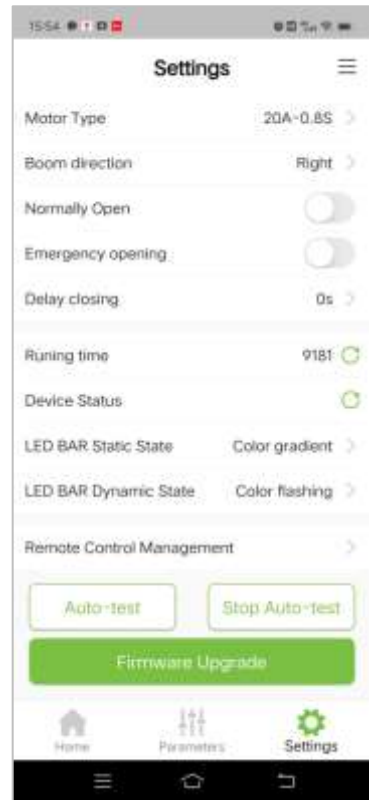
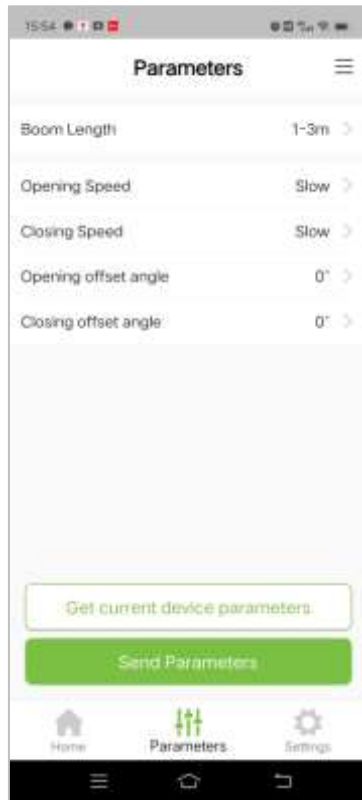

8 Functional Parameter Settings

After the initial installation, and first power-on, you must use the "Open" and "Close" buttons on the mainboard to complete the self-check process and learn the description of the menu.

8.1 Mainboard Parameter Settings

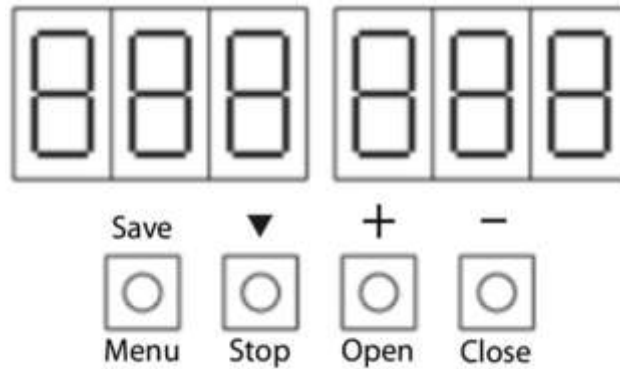

Menu/Save: Menu options/Confirm and Save.

Stop/▼: Stop the boom arm /Flip down the parameter.

Open/+: Increase parameter/value.

Close/-: Decrease parameter/value.

8.1.1 Operating Procedure

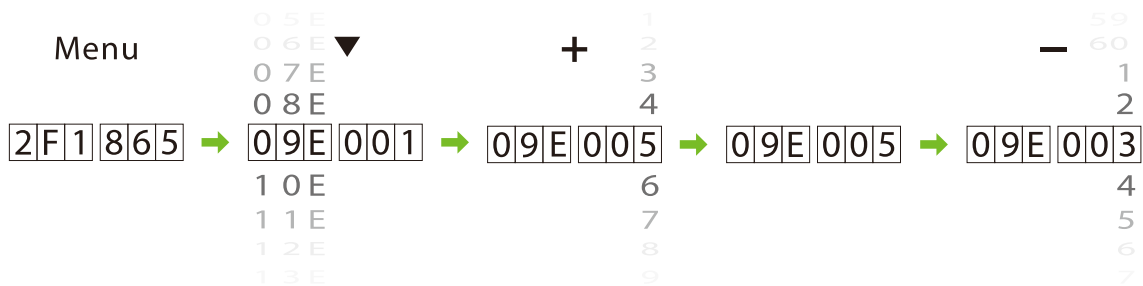
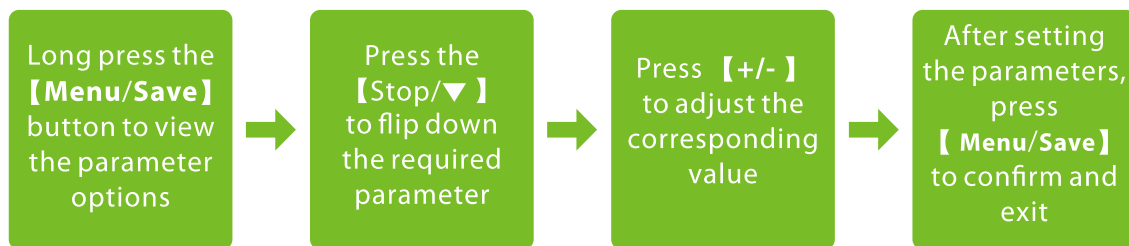

8.2 Parameter Settings Description

Item	Description	Default (1.5m boom)	Default (2m boom)	Default (3m boom)	Default (4m boom)
01EXXX	<p>Display Mode</p> <ul style="list-style-type: none"> 01E000: Displays current position of the swing arm 01E001: Controls input signal 01E002: Test mode (the digital LED displays "---" in the test mode) <p>01E102: Opening position 01E202: Closing position 01E502: Opening 01E602: Closing 01E702: In the pause</p> <ul style="list-style-type: none"> 01E003: Number of boom openings 01E004: Version Information 	01E000	01E000	01E000	01E000
02EXXX	<p>Boom Arm Opening Speed</p> <ul style="list-style-type: none"> 02E000: Low 02E001: Medium 02E002: Fast 02E003: Very Fast <p>Adjust the corresponding speed according to the boom arm length.</p>	02E003	02E003	02E003	02E001
03EXXX	<p>Boom Arm Opening Brake Stroke</p> <p>The larger the number, the longer the deceleration time and the more stable the boom arm operation. The Boom Arm Opening Deceleration Distance can be set between 10 to 25 and the default value is 20.</p>	03E018	03E022	03E021	03E025
04EXXX	<p>Boom Arm Opening Brake Speed</p> <p>The smaller the number is, the slower the deceleration, valid value: 2 to 30.</p>	04E015	04E024	04E027	04E030
05EXXX	<p>Boom Arm Closing Speed</p> <ul style="list-style-type: none"> 05E000: Low 05E001: Medium 05E002: Fast 05E003: Very Fast <p>Adjust the corresponding speed according to the boom arm length.</p>	05E003	05E003	05E003	05E001

06EXXX	<p>Boom Arm Closing Brake Stroke</p> <p>The larger the number, the longer the deceleration time and the more stable the boom arm operation. The Boom Arm Closing Deceleration Distance value can be set between 10 to 25 and the default value is 20.</p>	06E020	06E024	06E024	06E025
07EXXX	<p>Boom Arm Closing Brake Speed</p> <p>The smaller the number is, the faster the deceleration, valid value: 2 to 30.</p>	07E028	07E028	07E028	07E030
08EXXX	<p>Force Adjustment</p> <p>The larger the number, the greater the efficiency of the boom arm opening and closing force, valid value: 5 to 50.</p>	08E005	08E005	08E005	08E005
09EXXX	<p>Close Limit Adjustment</p> <p>Press [+/-] to adjust the position according to the situation and press [Menu/save] to save, which can be set between 1 to 60.</p>	09E005	09E005	09E005	09E016
10EXXX	<p>Open Limit Adjustment</p> <p>Press [+/-] to adjust the position according to the situation and press [Menu/save] to save, which can be set between 1 to 60.</p>	10E005	10E005	10E005	10E020
11EXXX	<p>Automatic Closing Time for Unmanned Passage</p> <p>Set the time to automatically close the boom arm after successful verification but no one passes, the larger the number, the longer it takes to close the boom arm, valid value: 5 to 60.</p>	11E000	11E000	11E000	11E000
12EXXX	<p>Boom Arm Opening Memory</p> <ul style="list-style-type: none"> ● 12E000: Close ● 12E001: Open <p>When more than two legal access signals are given at the same time (including the same direction and the opposite direction), the system will remember all pass requests and complete each pass in turn.</p>	12E000	12E000	12E000	12E000
13EXXX	<p>Core Component Position</p> <ul style="list-style-type: none"> ● 13E000: Right ● 13E001: Left 	13E000 or 13E001	13E000 or 13E001	13E000 or 13E001	13E000 or 13E001

14EXXX	<p>Reset</p> <ul style="list-style-type: none"> 14E000: -Normal 14E001: Reset <p>Select [14E001] will restore the default factory setting. (Note: The function does not clear Core Component Position and Core Component Polarity.)</p>	14E000	14E000	14E000	14E000
15EXXX	<p>Remote Control Pairing</p> <ul style="list-style-type: none"> 15E000: Normal 15E100: Add 15E200: Clear <p>Note: The fourth digit is adjusted by pressing [+/-] to add or clear wireless remotes, and the sixth digit shows the number of remotes that have been paired with the current device.</p>	15E000	15E000	15E000	15E000
16EXXX	RS485 Address	16E000	16E000	16E000	16E000
17EXXX	<p>Ground Sense Delay Time Setting</p> <p>Set the ground sense delay time by press [+/-] button, the larger the number set, the longer the delay time, the valid value is 0 to 251.</p>	17E000	17E000	17E000	17E000
18EXXX	<p>Core Component Type</p> <ul style="list-style-type: none"> 18E000: 20A to 0.6S 18E001: 18B to 1.2S 18E002: 18B to 2.5S <p>Please set the parameters according to the core component.</p>	18E000	18E000	18E000	18E000
19EXXX	<p>Boom Arm Type</p> <ul style="list-style-type: none"> 19E000: 1 to 3m 19E001: 3.5 to 4.5m 19E002: 5 to 6m <p>Please set the parameters according to the boom arm length.</p>	19E000	19E000	19E000	19E001
20EXXX	<p>Core Component Polarity</p> <ul style="list-style-type: none"> 20E000: Forward 20E001: Reverse 	20E000(L) or 20E001(R)	20E000(L) or 20E001(R)	20E000(L) or 20E001(R)	20E000(L) or 20E001(R)
21EXXX	<p>Power-off Open Mode</p> <ul style="list-style-type: none"> 21E000: Disable 21E001: Enable 	21E001	21E001	21E001	21E001

22EXXX	<p>Open/Close Limit LED State</p> <ul style="list-style-type: none"> 22E000: Open limit green light breathing, Close limit red light breathing 22E001: Open limit green light always on, Close limit red light always on 22E002: Open limit green light flashes, Close limit red light breathing 	22E000	22E000	22E000	22E000
23EXXX	<p>Open/Close LED State</p> <ul style="list-style-type: none"> 23E000: The red light flashes during the whole process of opening and closing the boom arm. 23E001: The red light is always on during the whole process of opening and closing the boom arm. 	23E000	23E000	23E000	23E000
24EXXX	<p>Remote Control Type</p> <ul style="list-style-type: none"> 24E000: 433MHz frequency 24E001: 430MHz frequency 	24E000	24E000	24E000	24E000

8.3 Error Code

Erro Code	Description	Solve
EL0002	Power-on Self-test failure, Hall limit detection error.	Check the spring and boom arm blance.
EL0004	Run Timeout.	Restart the machine
EL0008	Clutch Locked.	Check the 20E parameter
EL016	The code disk detection failed.	Check the motor connect cable; Check the 20E parameter.
EL032	Electric Motor Shaft Lock Protection failure.	Check the 20E parameter; Restart the machine.

8.4 Remote Control Pairing and Unpairing(Support setting on the ZKBarrier APP)

8.4.1 Pairing

Long press [Menu/save], then press [Stop/▼] flip down to [15EXXX]. Press [+/-] to set the parameter value. At this time, the LED display value is "15EX0X", and then press any button on the remote control

until you hear a beep sound from the Mainboard, it means the pairing is successful, and then press [Menu/save] exit the menu.

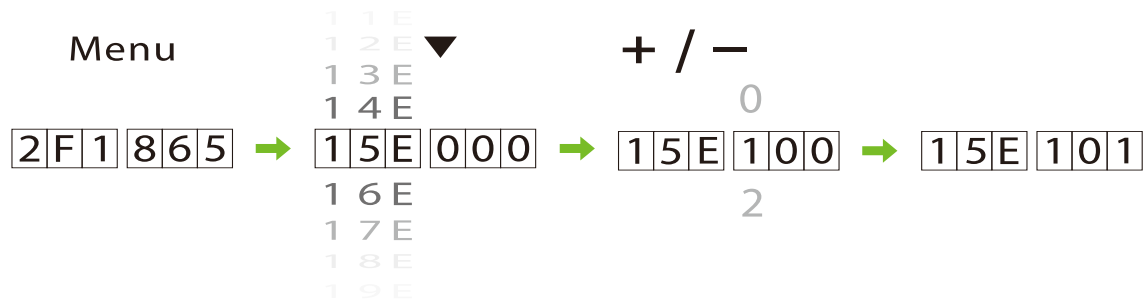

8.4.2 Unpairing

Long press [Menu/save], then press [Stop/▼] flip down to [15EXX]. Press [+/-] to set the parameter value, and then set the parameter value to "15E200". Press [Menu/save] to save the setting and that all the remote controls have been deleted.

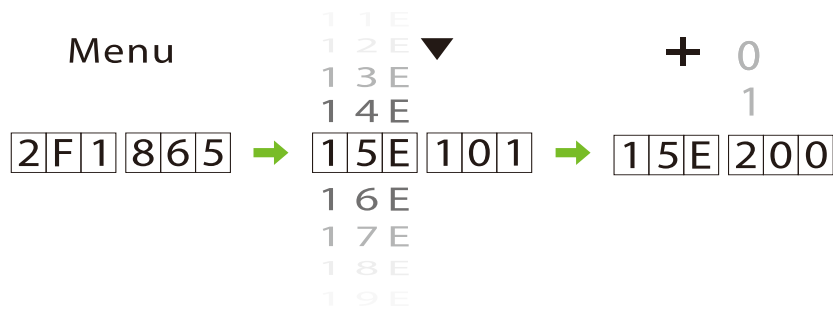

8.5 Set Delay for Automatic Closing after Opening the Boom Arm(Support setting on the ZKBarrier APP)

Long press the [Menu/save] button, then press [Stop/▼] flip down to [11EXXX] parameter, and then press the [+/-] to set the parameter value after selection. Set the delay value as per the requirements. Finally, press [Menu/save] to exit the menu. For example, if it is set to "11E007", the device will automatically close after 7 seconds after opening the barrier gate.

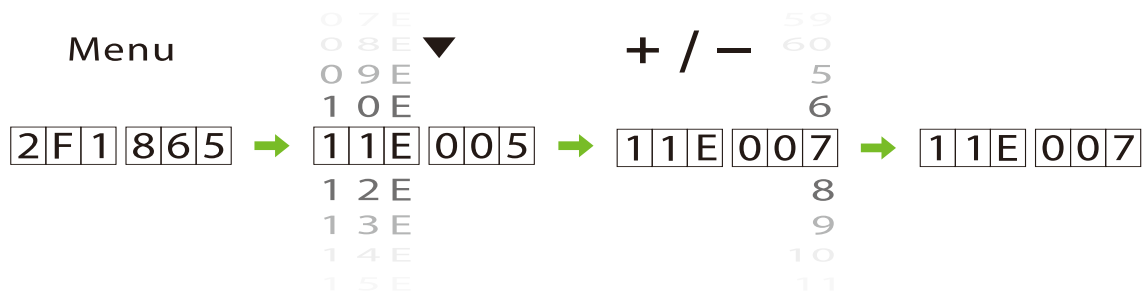

9 Boom Arm Adjustments

9.1 Dimensions

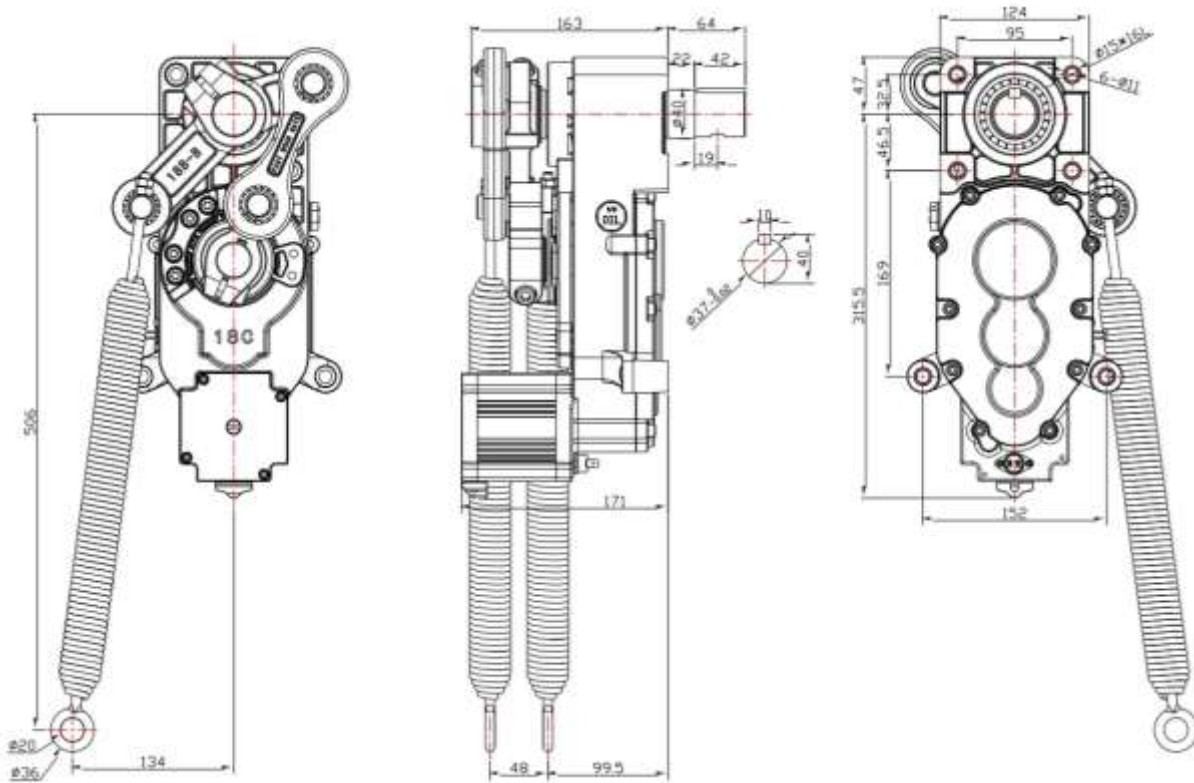

9.2 Horizontal and Vertical Angle Adjustment of Boom Arm (Mechanical Adjustment)

Note: The horizontal and vertical angles of the boom arm have been adjusted before leaving the factory. Please do not adjust them without the guidance of professionals to avoid mechanical damage.

- Adjust the Horizontal Position of the Boom Arm

The connecting boom crank will be an overlapping structure, with the connecting boom arm's two rotation points coincident with the reducer's output shaft at three points and a line. The boom arm is in this position horizontally. If the boom arm is not level or inclined at this time, unscrew the two rocker (spindle connecting arm) screws, turn the boom arm to the level, and tighten the screws.

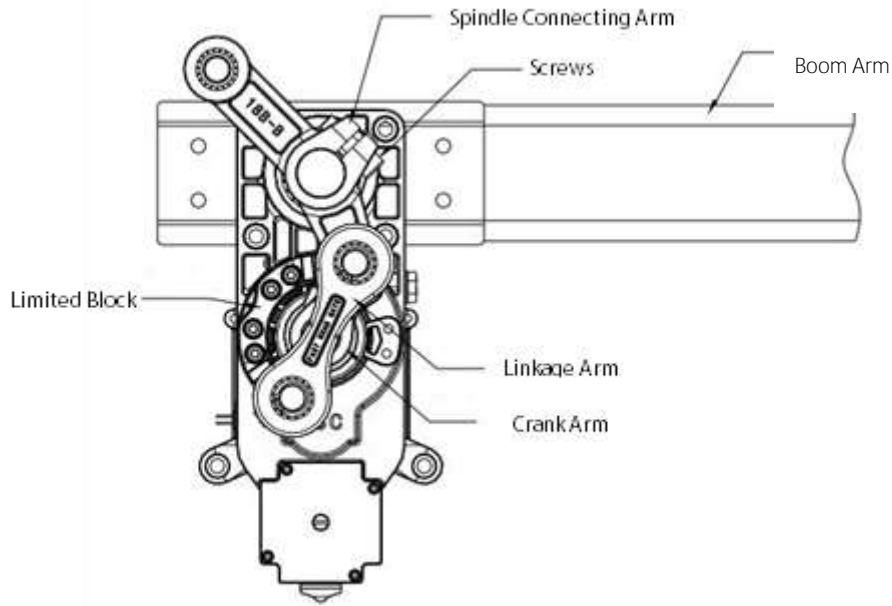

- Adjust the Vertical Position of the Boom Arm (Adjusted by Mechanical Structure)

The connecting boom arm crank is in an unfolded shape, and the connecting boom arm's two rotation points and the reducer's output shaft are in an unfolded 3-point line. This is the boom arm's vertical position. If the boom arm is not in the vertical position and is inclined, unscrew the two screws on the rocker (spindle connecting arm), rotate the boom arm to the vertical, and tighten the screws..

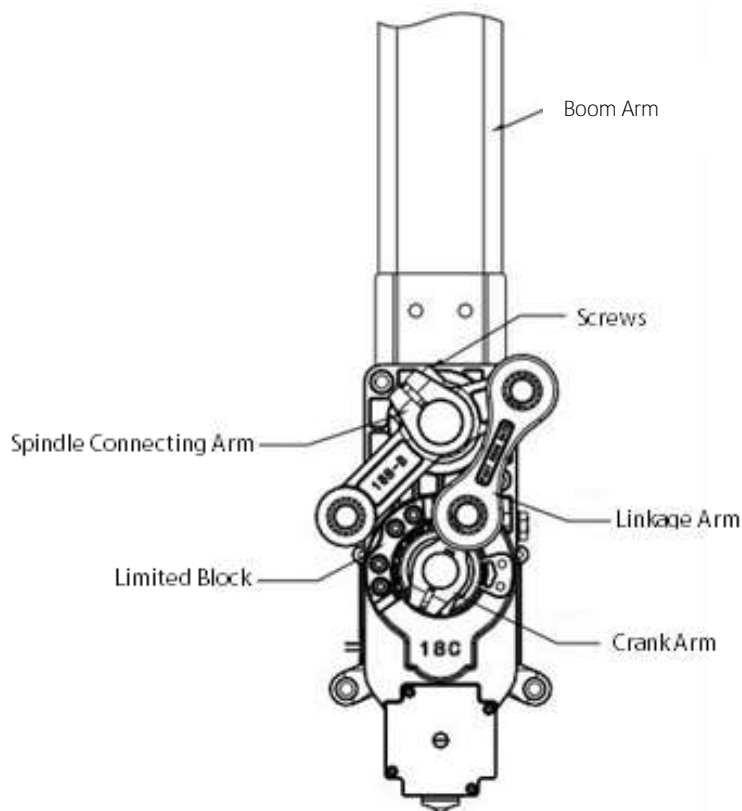

9.3 Direction Interchange of the Boom Arm

The operation steps are as follows:

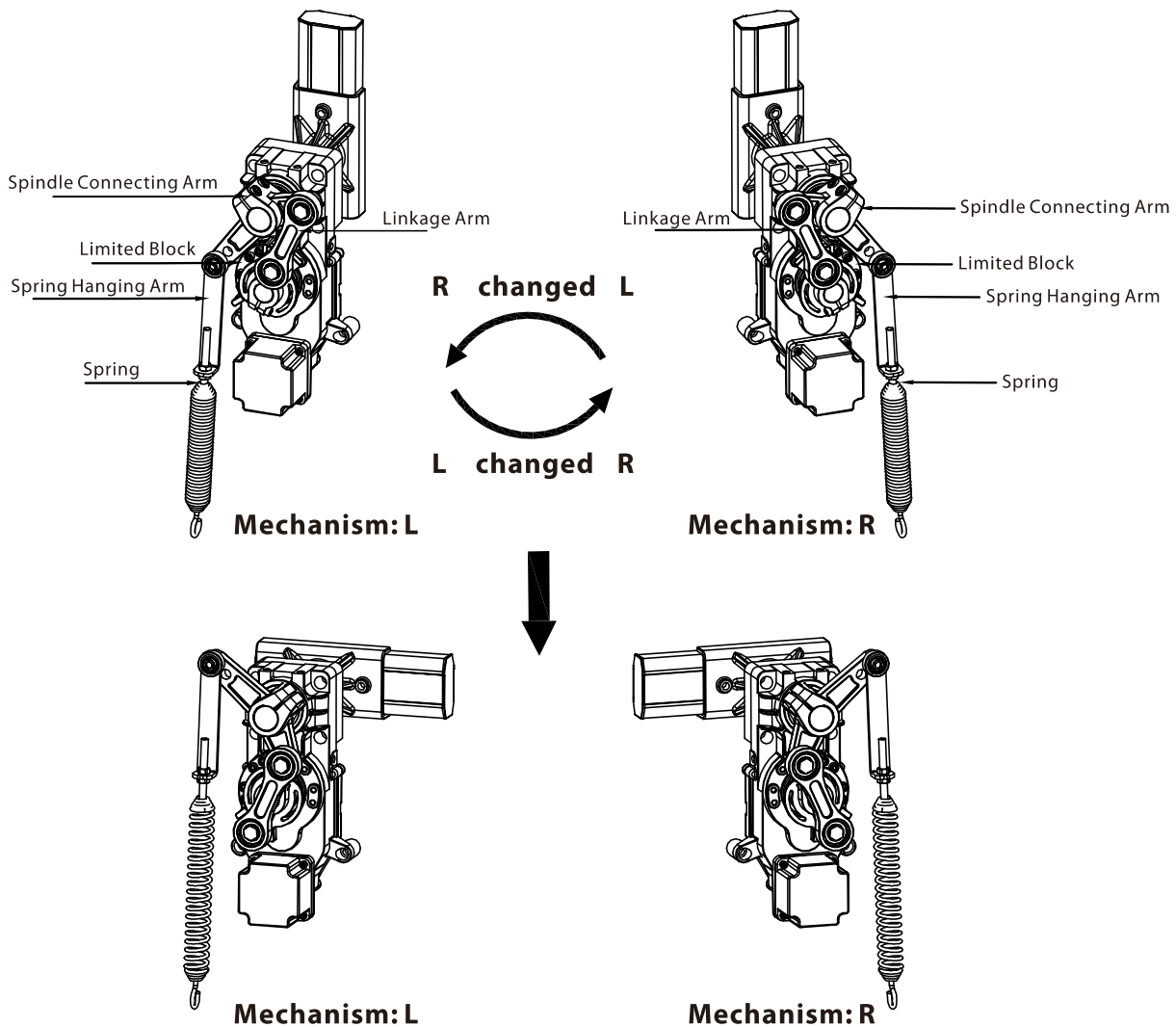

1. Before operation, please turn off the power. Remove the spring, spring hanging arm and boom.
2. Replace the new direction of the spindle Connecting Arm.
3. Change the linkage Arm.
4. Turn the Limited Block to the other direction.
5. After the mechanical operation, you need to set the movement parameter 13E Core Component Position on the motherboard, such as changing from L to R, the value of this parameter should be set from 1 to 0, or set the direction of the movement on the app.

9.4 Spring Adjustment

If the boom arm shakes when it rises, you can adjust the spring loosely, and if the boom arm shakes when it falls, you can adjust the spring tightly.

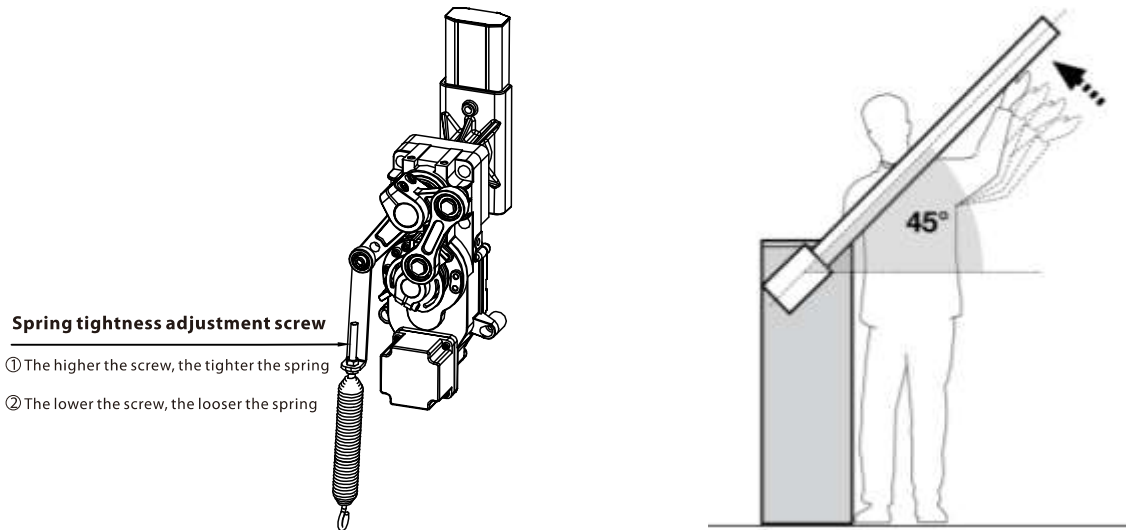

Note:

1. When the barrier boom is at 45°, it is the best balance.
2. The spring wire diameter is adapted to different boom lengths.

Boom length	Spring size and quantity	Spring Color logo
1.5m	No need	/
2m	3.5mm *1	Blue(3.5mm)
3m	3.5mm *1 + 4.0mm*1	Blue(3.5mm); Green(4.0mm)
4m	4.0mm *1 + 4.5mm*1	Green(4.0mm); Yellow(4.5mm)

10 Product Packing List

Material	Quantity
Chassis Explosion Screw	4
Keys	2
Barrier Boom	1
Chassis Pressure Plate	4
Wireless Remote	2
Barrier Boom hexagon bolt	1
Machine	1

11 Troubleshooting

Description: The Power Supply has a 24V output, but the mainboard power indicator does not light up.

Cause:

1. 24V output wiring might be reversed.
2. The mainboard might work abnormally.
3. Loose wiring.

Solution:

1. Swap the DC output wiring.
2. Replace the Mainboard.
3. Tighten the wiring.

Description: The AC input is normal, but the power indicator is off.

Cause:

1. The power fuse might be blown.
2. Abnormal power supply.
3. Loose wiring.

Solution:

1. Replace the fuse.
2. Replace the power supply.
3. Tighten the wiring.

Description: The power indicator is on, the landing boom indicator is normal, and the motor is not running.

Cause:

1. The motor wiring might be wrongly connected, or the wiring is loose.
2. The internal encoder of the motor may work abnormally.
3. The motor stroke limit exceeds the position.

Solution:

1. Check the wiring according to the wiring diagram, and tighten the wiring if required.
2. Replace the motor.
3. Re-adjust the motor limit parameters.

Description: The remote-control buttons do not respond.

Cause:

1. The remote-control battery is completely discharged.
2. There must be a signal interference with the same frequency and there might be some obstacles too nearby.
3. The remote-control frequency is not matched, or the receiver is damaged.

Solution:

1. Replace the battery.
2. Use manual button control.
3. Use in open areas.
4. Replace the remote control to re-match or replace the receiver.

Description: When the boom is closed halfway, it bounces back to the open state.

Cause:

1. The barrier boom might not be installed.
2. The spring is too tight, or the length of the barrier boom is changed, and the spring is not properly adjusted.

Solution:

1. Install the barrier boom.
2. Adjust the spring according to the length of the barrier boom.

12 Safety Precautions

- It is strictly forbidden to hit the product with hard objects.
- When using, please handle with care to avoid strong collision with hard objects.
- Do not spill water or corrosive liquids on the surface of the product.
- If smoke or a peculiar smell comes from the product, disconnect the power immediately.

Note: If the product works abnormally, please contact the dealer in time. Please do not try to repair it by yourself. If you handle it without authorization, the company is not responsible for any damage.

13 Transportation and Storage

- When loading and unloading the product, handle it with care.
- During transportation and storage, place it in a dry and corrosive-free environment. The product should be protected from moisture, rain, sun, and corrosion.

14 Warranty

This product promises a warranty period of 2 years. Upon normal use of the product, damages are covered by the warranty. However, damages caused by the following conditions are not covered by the warranty.

- Damages caused by incorrect operation and violation of operating procedures.
- Damages caused by repairing the product without authorization.
- Abnormalities and damages caused by extremely harsh operating conditions and operating environment beyond the machine's ability to withstand.
- Damages caused by irresistible factors (such as earthquake, tsunami, typhoon).

B-1, Khata No.31, Devasandra Industrial Estate,
Whitefield Main Road, Beside Phoenix Mall,
Mahadevapura, Bengaluru, Karnataka.

Phone : 080 6828 1342

www.zkteco.in

